

**Hydro
Gate**

Flap Gates

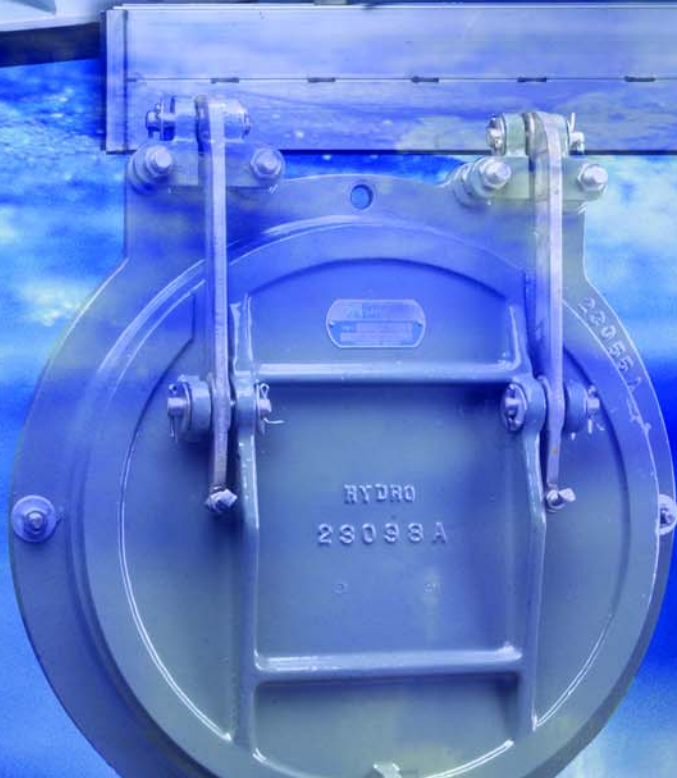

Pioneers in Gate Design

Hydro Gate 

3888 E. 45th Ave.
#120
Denver, CO 80216



With more than 100 years of experience in gate design, Hydro Gate has built a long-standing reputation of providing superior quality water control gates for a variety of industries. Our manufacturing expertise revolves around making big, heavy-duty gates that are 100% custom-built to match specific applications.

Commitment to You... Our Customer

At Hydro Gate, customer satisfaction is our top priority. Bring your special requirements to our engineers who have years of experience in gate design. Our dedicated customer service staff is accustomed to custom requests, because that is what we do best. From your first contact through final delivery, our team of engineers and service experts are here to make sure you have the right gates to suit your needs.

Your Source for Water Control Gates

No matter what type of gates your project demands, chances are excellent Hydro Gate has the right gates for your specific application. Our product offering is vast and can suit applications for a wide variety of industries. Choose from cast iron slide or flap gates, fabricated slide or flap gates, rectangular butterfly gates, stop logs, wall thimbles, lifts and accessories.

Industries We Serve

Whether you need gates for flood control, wastewater treatment, environmental water treatment, irrigation, dam projects or hydroelectric plants, we can help. From standard configurations to custom designs, Hydro Gate offers a wide variety of water control gates as well as a full complement of actuators to meet your specific application.

Service Well Beyond Shipment

Our services extend beyond manufacturing. Hydro Gate's experienced field service technicians can help you with repair and refurbishment projects. If you have existing, yet serviceable gates, we can perform a retrofit that will extend their life and durability.

Focus on Quality

Hydro Gates expansive 90,000 square foot manufacturing facility utilizes precision equipment that allows us to merge time-tested gate design with cutting edge technology. We offer large scale manufacturing capabilities with the ability to produce cast iron gates up to 14' x 16' in size, and fabricated gates up to and over 20' in width or height.



Table of Contents

Flap Gates:

Applications.....	2
Description	2-4

Heavy-Duty Flap Gates:

Features.....	5
Description	5
Dimensional Data.....	6
Specifications	7

Flexible (Rubber) Flap Gates:

Applications.....	8
Description	8
Features.....	8
Specifications	9

Flap Gates



24" Heavy Duty Flap Gate

Applications

- Flood Control
- Municipal Projects
- Farm Levees
- Sewer Outfalls
- Industrial Waste Lines
- Water and Sewage Treatment Plants
- Tidal Drainage
- Irrigation Systems
- Pump Discharge Control

Description

Hydro Gate flap gates are made of cast iron or ductile iron, depending on the type of service. A small differential pressure on the back of the gate causes it to open automatically to allow discharge through levees, sewer lines or drainage conduits. When water on the face side of the gate rises above water on the back side, the gate closes automatically to prevent backflow.

Flap gates are equipped with flat-back seats for attaching to wall thimbles, new concrete headwalls, existing walls or pipe flanges. The seat or frame of the flap gate is attached to a wall or pipe flange and forms the opening through which water passes. Since the gate opens or closes automatically, a mechanical lifting device is not necessary.

Automatic drainage gates must be kept clean if they are to function correctly. The hinged flap acts as a natural skimmer to cause timber, logs or trash to catch between the flap and the seat at low flow. Periodic inspection and cleaning should be scheduled when the water flowing through the flap gate carries floating material.

To make the gate more self-cleaning, it should be mounted 12 to 18 in. above the apron in front of the gate. This allows room at the bottom for floating material to work its way out and makes the gate flap somewhat self-cleaning.

Seat (Frames)

A seat (or frame) is a one-piece casting. The seating face is cast and machined at an angle off vertical so that the hinged cover has a horizontal force component to completely seat the gate by gravity.

Corrosion-resistant seating faces are pneumatically impacted into dovetail grooves for heavy-duty gates. All seating faces (above 4" diameter) are machined flat and to a 63 micro-inch finish.

When rubber seats are specified, the gumdrop cross-section rubber seal is locked into a deep dovetail groove in the seat.

Flaps (Covers)

Flaps are iron castings of reinforced flat plate design. Reinforcing ribs (both horizontal and vertical) are cast integrally along with bosses for the hinges.

Corrosion-resistant seating faces are attached as described in the previous section for frames.

Double-Hinge Action

For proper seating of a flap gate, double-hinge action is necessary. The main hinge action on any flap gate is about its upper pivot points. However, flexibility is required at the bottom pivot points to allow seating of the flap against the seat. All Hydro Gate flap gates have this double action with bushings at each pivot point.

It is necessary that bottom hinge action be limited. Otherwise, the flap can turn completely over on itself and wedge back in the opening of the gate seat, rendering the gate useless.

Heavy-duty circular opening flap gates are provided with hinge arms extending beyond the bottom pivot point. This limits the double-hinge action and prevents the flap from being rotated outward at the bottom. In addition, the bottom end of each hinge arm has a fine adjustment bolt to further limit the double-hinge action. Square or rectangular opening flap gates are also provided with extended links for fine adjustment even though the bottom of the flap cannot be turned into the gate opening as in the round gates.

Lubrication of Pivot Points

Lubrication of pivot points on flap gates is usually not necessary. The construction of the hinge assembly permits only a few degrees of rotation at the bottom pivot points. The gate cover rotates about the upper pivot points through an arc of 90° or less. With this limited rotation, lubrication of bushings is usually not justified nor is it normally recommended by Hydro Gate. When lubrication of flap gate pivot points is desired, two methods can be used:

1. A permanently lubricated bushing is installed at the factory. If lubrication of pivot points is desired, Hydro Gate recommends the permanently lubricated bronze bushing; or
2. Links or hinge arms can be drilled for zerk-type grease fittings for use with ordinary grease guns.

Loss of Head Through Flap Gates

Tests conducted on flap gates show that the loss of head due to the flap riding on the water is very small compared with other losses in the hydraulic structure. Of these head losses, the entrance loss is usually considerably more critical than loss at the flap gate on the outlet end of the conduit.

The Hydraulic Laboratory of the State University of Iowa conducted a series of tests to determine the amount of head lost by water discharging through Model 10C flap gates (formerly Armco-Calco). The gates — 18, 24 and 30 in. in diameter — were supplied from commercial stock.

The following passage is excerpted from the report of Floyd A. Nagler, associate professor of mechanics and hydraulics, who supervised the tests.

“Based on these experiments the following empirical formula was derived to express the loss in head through Calco Gates of varying sizes and with different velocities of flow:

L = loss of head in feet

v = velocity of flow through gate in feet per second

d = diameter of outlet in feet

e = base of natural logarithms

g = acceleration of gravity, 32 ft/sec/sec

$$L = \left(\frac{4v^2}{g} \right) e \left(\frac{-1.15v}{\sqrt{d}} \right)$$

“It may be concluded from these experiments that the Calco gate in its hydraulic characteristics is all that the manufacturers have claimed for it. The small loss in head obtained through these gates demonstrates that their installation has little effect on the discharged capacity of drainage outlets.”

Heavy-duty flap gates have heavier flaps or covers than the gate model tested. As a result, head losses through these gates may be slightly more than those indicated by the tests.

Attachment to Concrete Wall or Pipe Flange

Since flap gates open when subjected to a back pressure, only a small unseating force is encountered. When a flap gate is under face or seating head, the force of the water pushes against the cover and only the weight of the gate itself is on the attaching bolts or anchors. For this reason, fasteners are needed only to hold the gate on the wall or flange. There is no hydrostatic force tending to separate the gate from the wall or flange.

In attaching a round heavy-duty flap gate to a pipe flange, the gate is partially drilled to match a 125 lb. ASME bolt circle with only a portion of the holes being used. The cost to full drill the gate seat, mate every hole in the flange, and furnish the additional corrosion-resistant bolts and install them is not justified.

Flanges must be installed perfectly flat. Any warpage of a flange is transferred to the gate seat, preventing the flap to seat properly, particularly at low differential head. (Perfectly flat is generally defined as within plus or minus 1/64 in. of a true theoretical flat plane.)

Adjustable Top Pivot Points

For the adjustable pivot point on Hydro Gate heavy-duty and medium-duty flap gates, four holes are drilled and tapped – two per side – in the flat ears at the top of the gate seat (see Figure 6-1). Threaded studs are screwed into these holes and are securely locked in position.

A double-eared adjustable pivot lug is then placed on these two studs, and hex nuts are placed on both sides of the bosses. Another double set of ears projects to the top of the pivot lug for mounting of the hinge arms. A bushing in the hinge arm works on the body of the assembly pin. This arrangement allows the assembly pins through all pivot points to be in double shear for added strength and also provides for minimum lateral movement of the flap during gate operation.

With the double-nut arrangement on each stud, the top pivot lug can be moved in and out from the wall to vary the location of the top pivot point with respect to the seating face of the gate. All adjusting can be accomplished without removing the gate flap cover from the gate, as is necessary for other pivot arrangements.

The force required to open the gate increases as the pivot lug is moved back toward the wall. When the gate is in a tidal zone or when the gate is partially submerged, the pivot lug can be moved back as far as possible so that the weight of the flap keeps the gate closed. Where less pressure is needed to operate the gate, the pivot lugs are moved farther away from the wall.

Stainless Steel Bumper (Optional)

Gates mounted on a pump discharge pipe (not mounted on a head wall) or mounted in an area where excessive velocities occur should be specified to have a spring bumper (swing) to prevent the cover from being thrown over center over top of gate thus preventing the gate from closing automatically. It also prevents personal injury caused by a flap that is balanced or teetering over center. Designed for gate seat or wall mounting, depending on application or gate size.

Anti-Sway Bar

The anti-sway bar creates a uniform and rigid hinging operation of the gate by tying together all four hinge points. This prevents the gate components from “shaking themselves” loose and progression to failure.

Leakage

Leakage through flap gates decreases as head increases. At very low heads, there may be insufficient force to fully effect a tight, intimate fit of the seats, and somewhat greater leakage is likely.

Opening Pressure

Any significant depth of water behind the gate will cause the cover to unseat a crack and allow drainage. The pivot lug can be adjusted for more or less sensitivity. When adjusted for less sensitivity, greater depth of water (back pressure) will be needed to crack the gate open. Generally, flap gates cannot hold more than a few inches of backwater for an extended length of time.

Safety Notice

Gates (particularly smaller gates) in public areas should be fenced since children playing on or around them can lift the covers and be injured at the cover's pinch points.

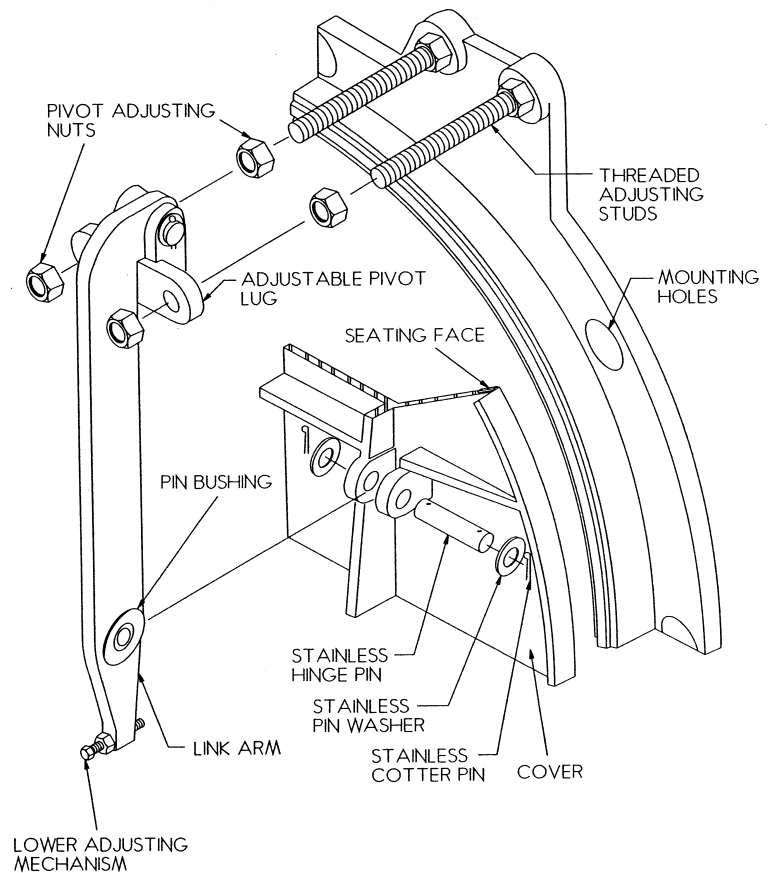

Figure 6-1
Adjustable Top Pivot and Link Assembly

Heavy-Duty Flap Gates



60"x36" Rectangular flap gate installation

Features

- Model 50C (Circular)
- Model 50 (Square or Rectangular)
- Seating heads to 50 ft
- Round, square or rectangular opening
- Flat-back, corrosion-resistant fasteners
- Ductile iron links and lugs

Description

Flat-back seats are for attaching the gate to a concrete wall pipe flange or wall thimble. The back of this gate seat is machined to a plane and drilled. Studs or anchor bolts should be of the same material as gate assembly bolts.

Heavy-duty flap gates have fully adjustable top pivot points. Through the use of two threaded studs, the top pivot point can be moved laterally from the wall to adjust the sensitivity of the gate or to compensate for slight misalignment in installation. The threaded studs with double-locking nuts allow adjustment to be accomplished without disassembly of the gate. By moving the top pivot point back, additional head is required to open the gate as the weight of the flap keeps the gate closed and reduces fluttering action caused by waves. Links or hinge arms are ductile iron and holes at pivot points are bronze bushed. The hinge pins through the links are in double shear due to double-eared pivot lugs at the top of the link and double bosses on the flap at the bottom. All fasteners are furnished in Type 316 stainless steel, for all environmental applications.

A lifting eye is cast integrally with the flap cover to permit manual operation or to hold the gate open. A rubber seating face is recommended in the gate seat if the gate is attached to the discharge end of a pump where slamming action will occur. The seating face on the cover is bronze. This corrosion-resistant face is machined to a plane and makes contact with the rubber on the seat when the gate is closed. The rubber face on the seat is set in a machined dovetail groove that holds it firmly in position without the aid of bolts, pins or adhesive. The rubber face acts as a cushion for the flap as it closes under moderate slamming action. These gates are exceptionally watertight under higher face pressures because of slight deformation of the rubber faces.

Fabricated Heavy Duty Flap Gates

Hydro Gate has the capability to provide a fabricated version of the Heavy Duty Flap Gate for special applications. This type of gate can accommodate odd size requirements or enhanced corrosion resistance than the cast iron line. Fabricated Flap Gates are offered in aluminum, stainless steel, or carbon steel and are designed with rubber seating faces. The fabricated version of the flap gate is designed to have the same functionality and performance as the cast iron version.

Dimensional Data

Model 50C Round Opening for Heads to 50 Ft

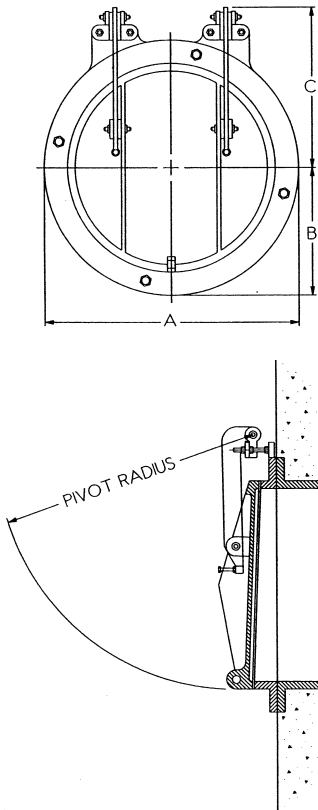

Opening Size Dia. (In.)	Dimensions (In.)			Pivot Radius (In.)
	A	B	C	
4	9.00	4.50	5.25	7.31
6	11.00	5.50	8.25	11.75
8	13.50	6.75	9.50	14.00
10	16.00	8.00	9.75	15.25
12	19.00	9.50	10.25	16.75
14	21.25	10.63	12.50	19.75
15	22.25	11.13	12.50	20.31
16	23.50	11.75	13.00	21.25
18	24.75	12.50	15.75	25.00
20	27.50	13.75	16.25	26.25
21	28.00	14.00	16.50	27.38
24	32.00	16.00	19.25	31.25
27	34.75	17.38	21.25	36.00

Opening Size Dia. (In.)	Dimensions (In.)			Pivot Radius (In.)
	A	B	C	
30	38.75	19.38	23.25	38.50
36	46.00	23.00	27.50	45.50
42	53.00	26.50	32.50	53.50
48	59.50	29.75	37.75	61.75
54	66.25	33.25	39.75	67.25
60	73.00	36.50	46.00	76.00
66	80.00	40.00	50.00	83.00
72	86.50	43.25	54.25	90.00
78	93.50	46.75	58.25	97.00
84	100.00	50.00	62.25	104.25
90	106.50	53.25	65.50	111.25
96	113.25	56.63	65.50	117.25
108	125.00	62.50	75.13	129.75

Figure 6-2 Heavy-Duty Flap Gate (Model 50C)

Model 50 Square and Rectangular Openings for Heads to 50 Ft

Opening Dia. (In.)	Dimensions (In.)			Pivot Radius (In.)
	A	B	C	
12 x 12	18.00	9.00	11.25	18.25
18 x 18	25.00	12.50	15.75	25.00
24 x 24	32.00	15.00	19.25	31.25
30 x 18	37.00	12.50	15.75	25.00
30 x 30	40.50	18.75	25.75	40.25
36 x 24	44.00	16.00	21.00	31.25
36 x 36	44.00	22.00	27.50	45.25
42 x 30	52.00	19.25	23.25	38.25
42 x 42	52.00	25.00	32.50	53.25
48 x 24	56.00	16.00	19.00	29.25
48 x 36	56.00	22.00	27.50	46.50
48 x 48	58.00	29.00	37.75	61.75
54 x 36	63.00	22.50	27.50	47.50
54 x 54	64.00	32.00	39.75	66.75
60 x 30	68.00	19.00	24.25	39.75

Opening Dia. (In.)	Dimensions (In.)			Pivot Radius (In.)
	A	B	C	
60 x 36	70.00	23.00	29.00	48.75
60 x 48	70.00	29.00	37.75	61.75
60 x 60	70.00	35.00	45.75	75.75
66 x 42	76.00	26.00	32.75	53.50
66 x 66	76.00	38.00	52.00	85.00
72 x 48	82.00	29.00	37.75	61.75
72 x 60	82.00	35.00	45.75	75.75
72 x 72	82.00	41.00	54.75	90.50
84 x 60	94.00	35.00	46.00	75.75
84 x 84	94.00	47.00	62.25	104.00
96 x 60	108.00	36.00	46.00	76.00
96 x 84	108.00	48.00	62.50	104.00
96 x 96	108.00	54.00	69.00	117.00
108 x 108	120.00	60.00	76.00	138.00
120 x 120	132.00	60.00	81.00	149.00

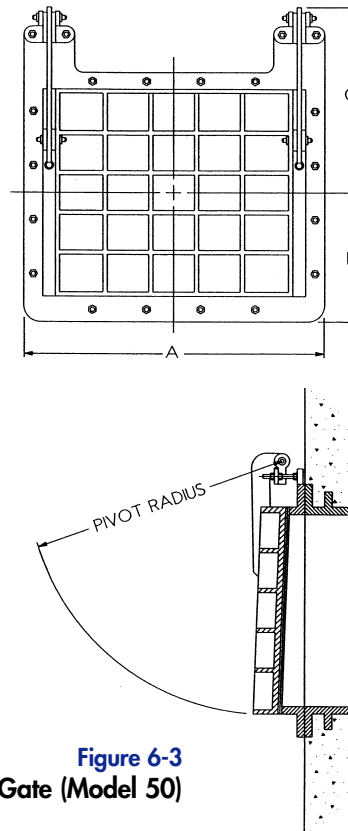

Figure 6-3 Heavy-Duty Flap Gate (Model 50)

Specifications for Heavy-Duty Flap Gates

General

Flap gates and accessories shall be of the size, material and construction shown on the drawings and specified herein. They shall be Hydro Gate heavy-duty flap gates or approved equal, with circular, square or rectangular openings. Similar installations shall have operated successfully for five years or more. All component parts shall be of the type material shown in the “Materials” section of this specification. The Material Combination Number applicable to each gate shall be shown in the “Gate Schedule.”

Seat

The seat shall be flat back and shall be cast in one piece with a raised section around the perimeter of the waterway opening to mount the seating faces. The raised section shall provide a seating plane diverging top to bottom from the plane of the mounting flange to assist in positive closure of the cover. The seat shall be shaped to provide two bosses extended above the top of the waterway opening for mounting the pivot lugs. Pivot lug bosses shall be drilled and tapped for mounting studs. The back of the seat shall be machined to a plane and drilled to mate the anchor or stud layout. Gates attached to concrete shall be mounted on anchor bolts and grouted in place.

Cover

The cover shall be cast in one piece with necessary reinforcing ribs, a lifting eye for manual operation, and with bosses to provide a pivot point connection with the links. Bosses shall be designed to place the hinge pins in double shear when the gate is assembled.

Seating Faces

A full-width, dovetail slot shall be machined around the perimeter of the cover and the seat. Corrosion-resistant dovetail seating faces shall be mounted in the slot and held securely without use of screws or other fasteners. The seating faces shall be machined to a plane with a minimum 63 micro-inch finish.

Flap gates subjected to pump discharge slamming action shall have a rubber seating face on the seat. Rubber seating faces shall be mounted in a dovetail slot and held securely without use of pins or screws. The seating face on the cover shall be as specified in the previous section.

Pivot Lugs

Each pivot lug shall be cast in one piece. Lugs shall have double bosses to place the top hinge pins in double shear when they are assembled through the link. The lugs shall be adjustable in the horizontal plane without removal of the cover from the gate links. The adjustment shall allow the top pivot point to be moved toward the gate seat for reduced sensitivity of the cover, or moved away from the gate seat to provide opening with minimum differential head. Two corrosion-resistant studs shall be used to connect each pivot lug to the gate seat.

Links

The links connecting the cover and pivot lugs shall be heavy duty and cast in one piece. Each link shall be provided with commercial grade, corrosion-resistant bushings at each pivot point. The bottom of the links shall be provided with an adjusting screw to properly align seating faces on the cover with respect to the seat. The links shall be designed to limit the double hinge

action, preventing the cover from rotating sufficiently to become wedged in the open position.

Fasteners

All anchor bolts, assembly bolts, screws, studs and nuts shall be of ample size to safely withstand the forces created by operation of the gate under the heads shown in the “Gate Schedule”. Quantity and size of the fasteners shall be recommended by the manufacturer. Anchor bolts shall be furnished with two nuts each to facilitate installation and alignment of the gates when attached to concrete.

Painting

Machined surfaces shall be coated with a water-resistant, rust-preventive compound. All cast iron parts shall be shop cleaned and painted in accordance with the manufacturer’s standard practice.

Drawings for Approval

Drawings showing the dimensions and details required to locate and install the component assemblies shall be submitted for the engineer’s approval prior to fabrication.

Installation

Installation of all parts shall be done by the contractor in a workmanlike manner and in accordance with the manufacturer’s instructions. It shall be the contractor’s responsibility to handle, store and install the gate in strict accord with the manufacturer’s drawings and recommendations.

Materials

Hydro Gate Flap Gates are manufactured in one standard material combination, as listed below. Various components of the flap gate are available in other materials when absolutely required by the customer. Any material variations are subject to additional costs. Optional materials listed below are not necessarily all inclusive. Please contact Hydro Gate engineering for any additional clarification on optional materials.

Seat and Cover

Standard Material: Cast Iron, ASTM A126, Class B

Optional Materials: Austenitic Gray Iron (Ni-Resist), ASTM A436

Ductile Iron, ASTM A536 Grade 80-55-06

Seating Faces

Standard Material: Silicon Bronze, ASTM B98, Alloy 651

Optional Materials: Neoprene, ASTM D2000, Grade 1BE625

Pivot Lugs

Standard Material: Ductile Iron, ASTM A536 Grade 80-55-06

Optional Materials: Austenitic Gray Iron (Ni-Resist), ASTM A436

Links

Standard Material: Ductile Iron, ASTM A536 Grade 80-55-06

Optional Materials: Austenitic Gray Iron (Ni-Resist), ASTM A436

Stainless Steel, ASTM A276, Type 304 or 316

Bushings

Standard Material: Bronze, ASTM B584, Alloy 932

Optional Materials: Self-Lubricating Bronze, (various)

Stainless Steel, ASTM A276, Type 304 or 316

Fasteners

Standard Material: Stainless Steel, ASTM F593 (Bolts), Alloy Group 2, Type 316

Flexible (Rubber) Flap Gates



These gates are available in a variety of sizes. For the minimum and maximum gate sizes available, please consult Hydro Gate's Engineering staff.

When specifying Hydro Gate's Flexible Flap Gate be sure to consider the characteristics of the water, the gate's function, the opening size and the maximum head requirements. Hydro Gate's Engineering staff is experienced in answering any of the questions you may have concerning the design and use of the Flexible Flap Gate.

Features

- Stainless steel frame (seat)
- Flexible fiber reinforced neoprene cover (flap), one inch thick for most applications
- Stainless steel reinforcing angles bolted to cover with full width stainless steel backer bar
- Resilient neoprene hollow bulb seal bolted to frame for seating seal
- Flexible continuous hinge integral with neoprene cover

Design and application features:

- Simple rugged design
- Low head loss, low cracking pressure, self draining
- Quiet operation, no slamming metal to metal
- Withstands pump discharge and reverse flow slamming and wave action
- Tolerates debris, cover molds around objects
- Corrosion resistant to most water born contaminates, resistant to algae and marine growth
- No painting, no lubrication, no broken hinges, links or worn pins
- Smooth design for easy flushing

Hydro Gate rubber flap gates are best suited for wall mounting on anchor bolts and grout pad. They can also be mounted on a fabricated or cast iron thimble; however, the back flange is unmachined which requires heavy layer of mastic or a thick soft gasket to seal the flange joint.

Gates larger (width or height) than 42 inches may require seaming and bonding of the rubber flap due to available rubber sheet width. Multiple gate openings or multiple gates may be used in lieu of a seamed rubber cover. Multiple gate openings prevent debris from catching in the frame members. Contact Hydro Gate Engineering Department for recommendation for your specific application.

Applications

- Very low unseating head requirements
- Pump discharge
- Coastal tide basin drainage
- Combined sewage overflow requirements

Description

Flexible Flap Gates are manufactured with a stainless steel frame and a reinforced neoprene cover. To aid in the sealing of the gate, a flexible neoprene seal is mounted to the stainless steel frame.

These gates are quiet operating and require very little maintenance. Should debris collect behind the cover it is easily removed or flushed out. These gates are ideally suited for pump discharge and wave action. There are no hinge pins to wear out and they never need painting. The Flexible Flap Gate can be mounted to a fabricated wall thimble or to a concrete wall with the incorporation of a grout pad.

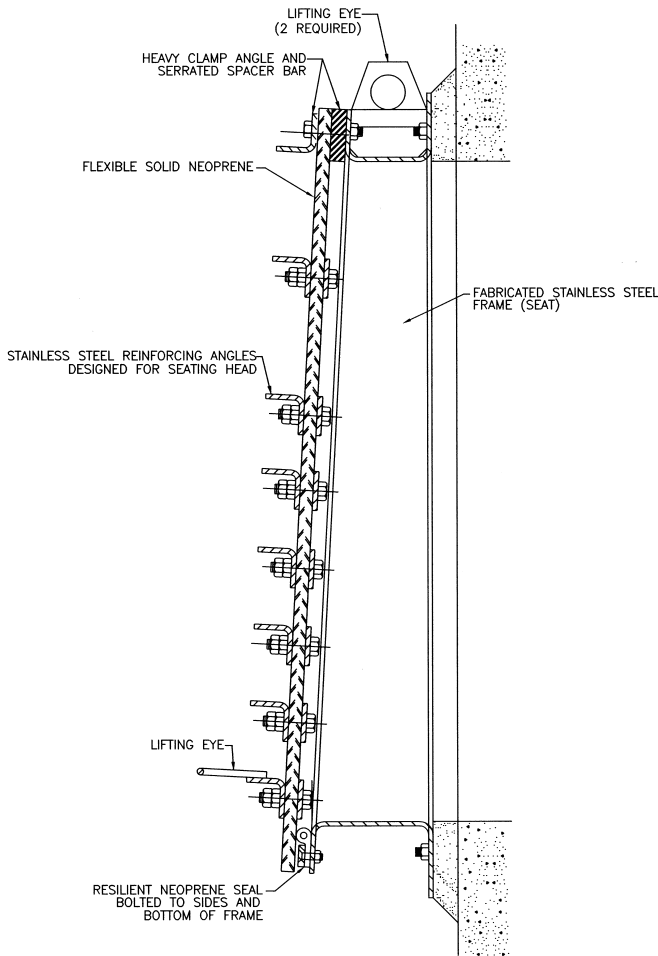

Rubber Flap Gate — Section View

Specification for Flexible (Rubber) Flap Gate

Flexible flap gates shall be of size and material grades as specified herein and as shown on drawings and gate schedule. They shall be Hydro Gate Flexible Flap Gate or approved equal. They shall be square or rectangular or multiple opening style.

Frame

Frame shall be fabricated from stainless steel type 304. The frame shall have a diverging face top to bottom to assist in positive closure of the flap. The frame shall be provided with a rear attaching flange, holes to mount, and a concrete structure with a grout pad. Two lifting lugs shall be provided on the frame for handling and installation hanging.

Cover (Flap)

The cover shall be fabricated from fabric reinforced neoprene rubber and type 304 stainless steel reinforcing angles attached to the rubber sheet with stainless steel through bolts and backing bars. The bolts shall be caulked or sealed to prevent leakage through the boltholes. The size and quantity of reinforcing beams shall be designed to withstand the maximum hydrostatic force applied to the gate. The hinge end of the cover shall be securely bolted to the frame with heaving clamping bars and bolts.

The rubber cover sheet shall be one piece without seams. The rubber thickness shall be sufficient to prevent excessive “ballooning” under hydrostatic pressure. Gate widths greater than available rubber sheet shall be furnished with multiple (side by side) openings.

The flap cover shall have a lifting lug at its lower end to facilitate lifting for cleaning.

Hinge

The hinge shall be flexible type integral with the flexible rubber cover.

Seating Surfaces

Resilient hollow section or lip type rubber seals shall be attached to the divergent face of the gate frame with bolts and stainless steel retainer bars. The resilient seals shall provide a high degree of water tightness.

Limitations

Hydro Gate wants to be sure that flexible flap gates will meet the requirements of the project. Before specifying gates wider than 60” and head pressures more than twice the gate height, contact Hydro Gate Engineering Department for design and material limits. Provide information about the type of service, type of water, maximum seating heads and mounting information.

Gate Schedule				
Quantity Required	Size of Opening (In.)	Back Type	Seating Head (Ft)	Remarks

*Our mission is to be
the leading water
control gate
manufacturer in
the world,
through continuous
development of
an organization
which promotes
extraordinary customer
service, superior
engineering, quality
products and
on-time delivery.*

Hydro Gate

*Your Source for Water
Control Gates*



**Toll Free 800-678-8228
303-287-8531 (fax)
www.hydrogate.com**